

Cartridge Filter Housings

Nowata H Series Vertical Multi-Cartridge

Designed for Use with Nowata High Flow Cartridges

Request a Quote Today!

1. Introduction

The H series, vertical cartridge housing has the unique design of assuring the elements are seated in the mount receptacles before the closure can be tightened. This prevents improper reseating of cartridges prior to being placed into service and also keeps possible system back pressure from dislodging the elements from their respective seals.

Housings that are 24 inches and under outside diameter feature a flat top style closure lid (as shown). Housings that are over 24 inches outside diameter utilize a dish top style closure.

Standard material of construction is carbon steel or stainless steel. In stainless steel construction, all wetted parts are stainless. The following non-wetted parts are made of carbon steel: Zinc plated bolts and nuts, davit arm assembly, leg assembly, and bolting lug assemblies.

Features

- Filter housings contain twice as much surface area for the same diameter vessel as competitive products
- Unique guide tubes for easy, accurate installation of cartridges
- Dual O-Rings on elements seal themselves as the vessel cover is tightened, insuring no liquid bypass. Springs or cups are not used
- Gauge ports and drain ports are pre-tapped making gauges and valves easy to install
- Multiple options for housing o-rings
- Optional boom and hoist are available to lift cartridges out of housing making the housing safer and easier to use than competitive vessels without this feature
- Optional air eliminator that releases air from the vessel which eliminates manual venting. Automatic venting insures full use of the available filter surface area
- Vessels meet ASME Code Section VIII, Division I which insures premium material and construction for safety, quality and longer vessel life



2. Dimensional Information

No. of Cartridges	Inlet/Outlet Size	B	C	D	E	F	G	H	J
4	4	78	18	24	6-1/2	27-1/2	12-1/2	13	5-1/2
5	4	79-5/8	20	26	7-1/2	28-1/2	13	15	6
7	6	84	24	28	9-1/2	36-3/4	19-1/8	17	6-1/2
11	6	91-3/8	30	34	12-1/2	38-1/8	19-1/8	21	6-1/2
18	8	101-1/8	36	33-3/4	14-3/4	46-5/8	24-5/8	24	8-1/2
21	8	116-1/2	42	45-15/16	16-5/8	48-3/4	24-1/8	29	8
29	10	127-3/4	48	52-3/4	21-3/8	57-1/2	28-5/8	32	9-1/2

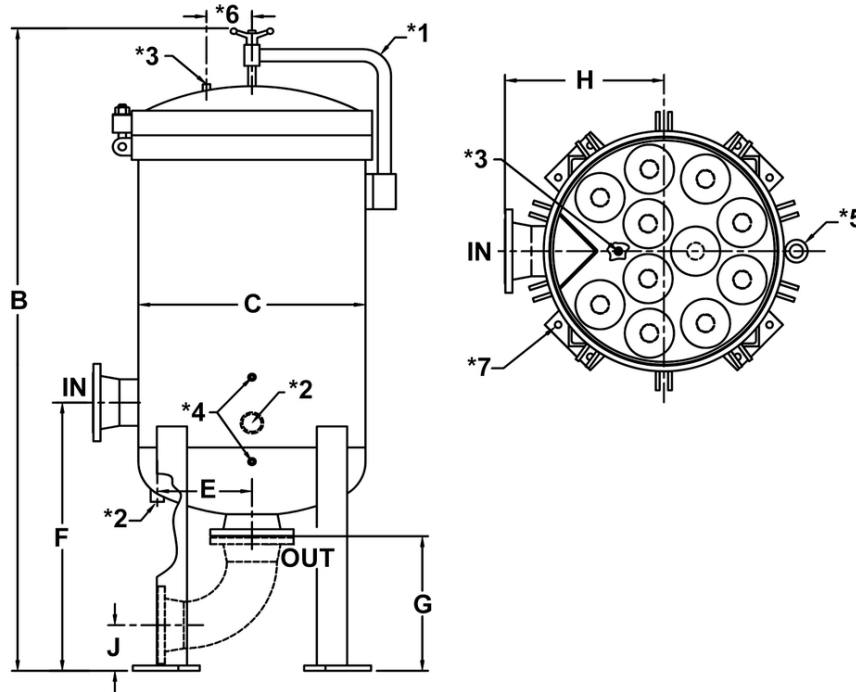

Dimensions in inches except where noted. Due to our continuing program of product improvement, specifications are for reference only and subject to change without notice. Dimensions are approximate values and not intended for piping specifications.

NOTES:

Inlet/outlet is ANSI 150 class

*1 = Davit arm assembly

*2 = Drain 2 inches, far side

*3 = Vent 1/4 inch FNPT

*4 = DP taps 1/4 inch

*5 = Davit pivot location

*6 = 6 inches

*7 = 7/8 inch on BC (typically 4 places)

3. Typical Model Number

H	V	U	11	Q	C	15	W	6	V
Nowata Series	Housing Orientation	Housing Material	Number Elements	Cartridge Length	ASME Code	Pressure Rating	Connection Type	Connection Size	O-Ring Material



Authorized MAHLE-Nowata Distributor & Representative

For pricing and information please call
Commercial Filtration Supply at (855)-236-0467

Visit us Online at: www.commercialfiltrationsupply.com
for more filtration products.